

EE 444

Wireless Transceiver

nRF24L01+

Roy Benmoshe

Overview

The goal of this presentation is to educate you on the NRF24L01+ transceiver. I will walk you through the steps that I went through in order to determine whether or not it is possible to accurately calculate the position of the robot in the maze.

You will learn about

- Types of distance measuring sensors
- The different types of transceivers I used
- The pros and cons
- How I tested the transceivers
- Where I failed and succeeded
- Other applications that it can be used for

Distance Sensors

LIDAR



LIDAR, which stands for **Light Detection and Ranging**, is a remote sensing method that uses light in the form of a **pulsed laser** to measure ranges (variable distances)

IR distance sensor

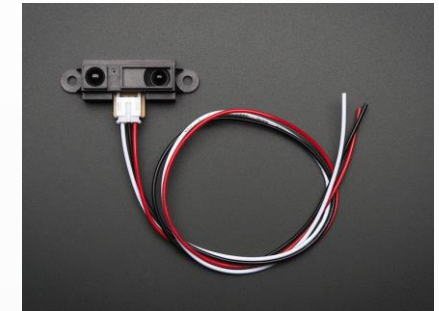

A **proximity sensor** often emits an electromagnetic field or a beam of electromagnetic radiation (**infrared**, for instance), and looks for changes in the field or return signal. The object being sensed is often referred to as the **proximity sensor's target**.

Ultrasonic Distance Sensor



The Ultrasonic Sensor sends out a **high-frequency sound** pulse and then times how long it takes for the echo of the sound to reflect back. The sensor has 2 openings on its front. One opening transmits ultrasonic waves, (like a tiny speaker), the other receives them, (like a tiny microphone).

https://en.wikipedia.org/wiki/Proximity_sensor

Sparkfun - LIDAR-LITE V3

<https://oceanservice.noaa.gov/facts/lidar.html>

<http://arduino-info.wikispaces.com/Ultrasonic+Distance+Sensor>

Wireless Transceiver

A transceiver is a device that contains a transmitter and a receiver which are both combined and share common circuitry. Transceivers combine a significant amount of the transmitter and receiver handling circuitry.

The term applies to **wireless** communications devices such as cellular telephones, cordless telephone sets, handheld two-way radios, and mobile two-way radios.

Based on sx1231 transceiver

[Adafruit \(PID 3071\) RFM69HCW Transceiver Radio Breakout - 433 MHz](#)



433Mhz Rf Transmitter and Receiver Module Link Kit

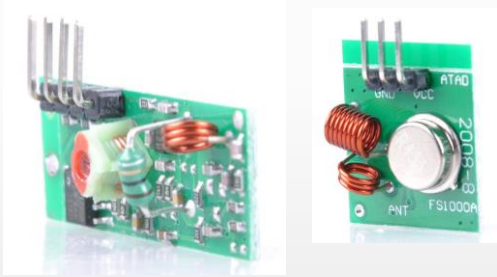

HC-06 Bluetooth



Based on nrf24lo1+ transceiver

SparkFun Transceiver Breakout - nRF24L01+

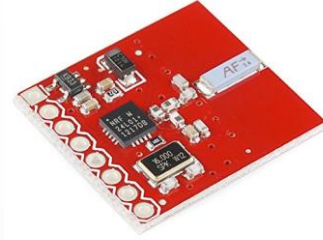

Wireless Module NRF24L01+PA+LNA

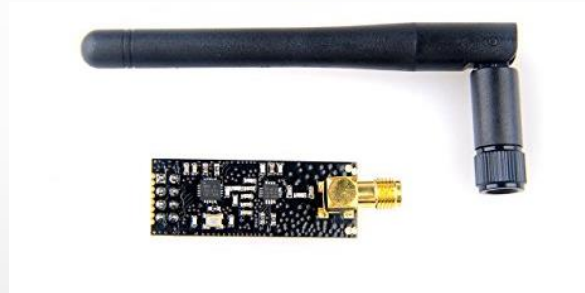

NRF24L01+ 2.4GHz Antenna Wireless Transceiver

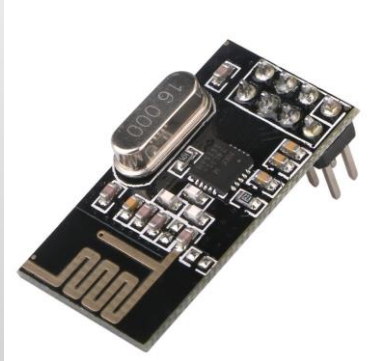

Based on ESP8266 WiFi chip

ESP8266 ESP-01S WiFi Serial Transceiver Module

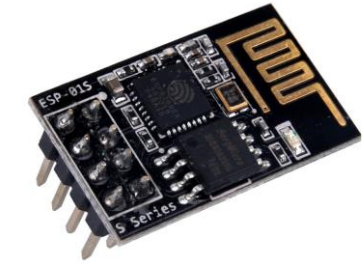

ESP8266 microcontroller NodeMCU Lua V3 WIFI with CH340G

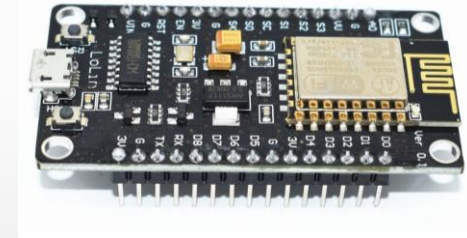

HUZZAH ESP8266 Breakout

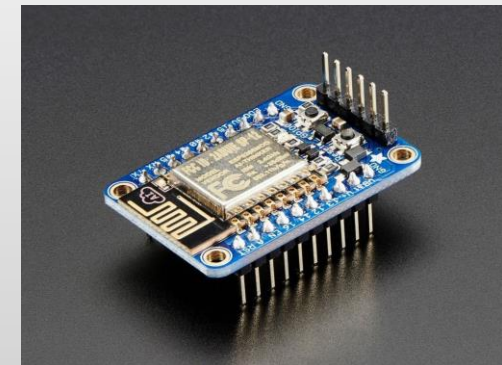

nRF24L01+ Transceiver IC

The Nordic nRF24L01+ is a highly integrated, ultra low power (ULP) 2Mbps RF transceiver IC for the 2.4GHz ISM (Industrial, Scientific and Medical) band.

With peak RX/TX currents lower than 14mA, a sub μ A power down mode, advanced power management, and a 1.9 to 3.6V supply range, the nRF24L01+ provides a true ULP solution enabling months to years of battery life from coin cell or AA/AAA batteries.

The Enhanced ShockBurst™ hardware protocol accelerator offloads time critical protocol functions from the application microcontroller enabling the implementation of advanced and robust wireless connectivity with low cost 3rd-party microcontrollers.

Pin	Name	Pin function	Description
1	CE	Digital Input	Chip Enable Activates RX or TX mode
2	CSN	Digital Input	SPI Chip Select
3	SCK	Digital Input	SPI Clock
4	MOSI	Digital Input	SPI Slave Data Input
5	MISO	Digital Output	SPI Slave Data Output, with tri-state option
6	IRQ	Digital Output	Maskable interrupt pin. Active low
7	VDD	Power	Power Supply (+1.9V - +3.6V DC)
8	VSS	Power	Ground (0V)
9	XC2	Analog Output	Crystal Pin 2
10	XC1	Analog Input	Crystal Pin 1
11	VDD_PA	Power Output	Power Supply Output (+1.8V) for the internal nRF24L01+ Power Amplifier. Must be connected to ANT1 and ANT2 as shown in Figure 29 .
12	ANT1	RF	Antenna interface 1
13	ANT2	RF	Antenna interface 2
14	VSS	Power	Ground (0V)
15	VDD	Power	Power Supply (+1.9V - +3.6V DC)
16	IREF	Analog Input	Reference current. Connect a 22k Ω resistor to ground. See Figure 29 .
17	VSS	Power	Ground (0V)
18	VDD	Power	Power Supply (+1.9V - +3.6V DC)
19	DVDD	Power Output	Internal digital supply output for de-coupling purposes. See Figure 29 .
20	VSS	Power	Ground (0V)

Table 1. nRF24L01+ pin function

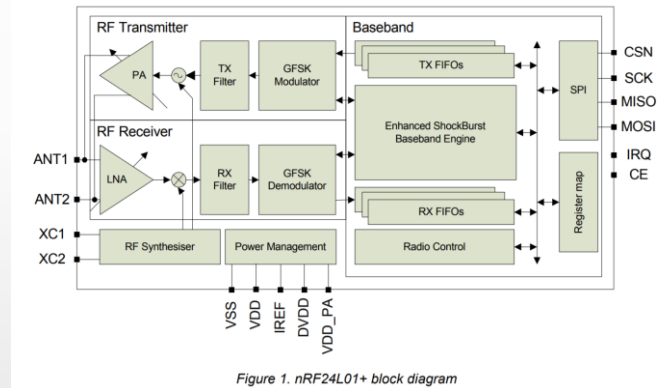
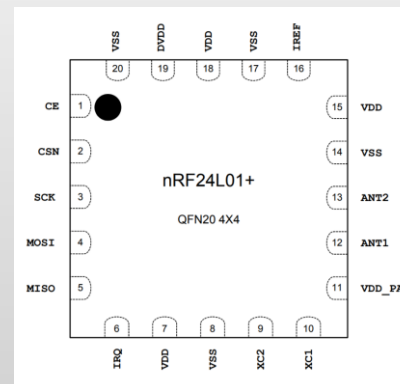

Figure 1. nRF24L01+ block diagram

Features

- Low cost, single-chip 2.4GHz GFSK RF transceiver IC
- Worldwide license-free 2.4GHz ISM band operation
- 250kbps, 1Mbps and 2Mbps on-air data-rate options
- Ultra low power consumption – months to years of battery lifetime



Symbol	Parameter (condition)	Notes	Min.	Typ.	Max.	Units
VDD	Supply voltage		1.9	3.0	3.6	V
VDD	Supply voltage if input signals >3.6V		2.7	3.0	3.3	V
TEMP	Operating Temperature		-40	+27	+85	°C

Table 3. Operating conditions

Wireless Transceiver Breakout

The goal:

- 1) Find the best transceiver to transmit data **CONSISTANTLY**
- 2) Determine distance using ping
- 3) Determine positioning using trilateration

NRF24L01+

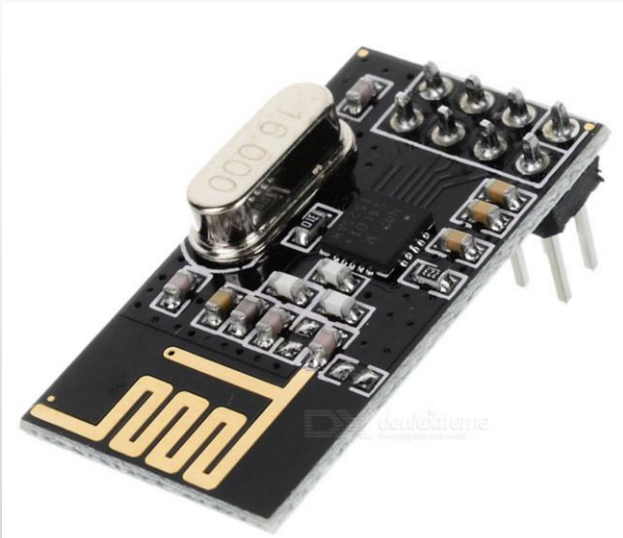

NRF24L01+PA+LNA



SparkFun Transceiver

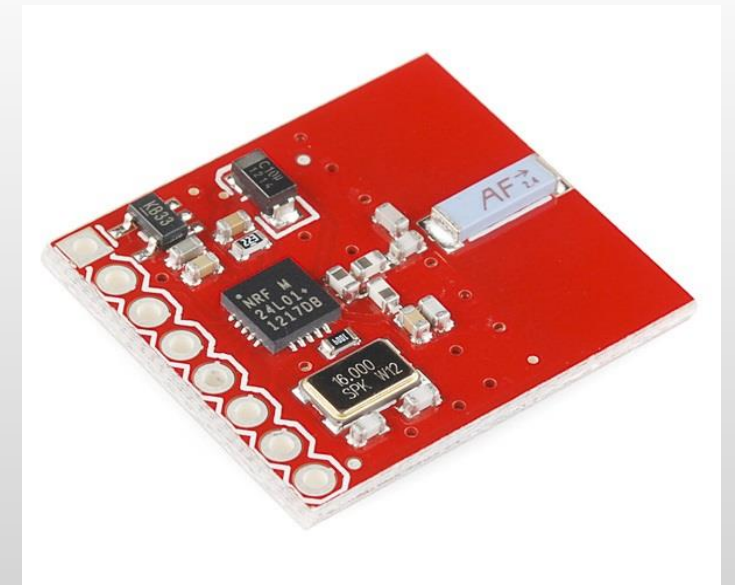

2.4GHz

When considering if 2.4Gz wireless is suitable for your projects, some of the considerations you would look at include cost, ease of use, availability, range and bandwidth.

One of the most common wireless modules around today is the nRF24L01. It is not only cheap, but relatively easy to use and can be used for short or long range communications.

Your router, your cordless phone, your Bluetooth earpiece, your baby monitor and your garage opener, car alarm, microwave, video devices, wireless mics, etc... Generally use 2.4 GHz transmission

A 2.4-GHz system will have a longer range (if unobstructed) and generally requires a smaller antenna, which keeps the phone's size in check.

The range is 2.400 to 2.525 Ghz which is 2400 to 2525 MHz. The nRF24L01 channel spacing is 1 Mhz which gives 125 possible channels numbered 0 .. 124.

There are five different bands used for Wi-Fi transmissions: 2.4GHz, 3.6GHz, 4.9GHz, 5GHz, and 5.9GHz. How the bands are used varies from one country to another. The most widely used is the 2.4GHz..

2.4GHz Antenna

The antenna is a dipole. One half of the dipole is the white wire that protrudes to the left, and the other half of the dipole is the metal cylinder. Each half is electrically insulated from the other, and is approximately $\frac{1}{4}$ wavelength long.

The **wavelength** of a 2.45GHz signal is **122.45 mm**.

A dipole at 2.45GHz is 61.22 mm from end to end, and each of the two halves is 30.61 mm.

Working in inches, a dipole at 2.45GHz is 2.41" from end to end, and each of the two halves is 1.205".

The elements are quite small in the 2.4GHz band, and even smaller in the other four bands.

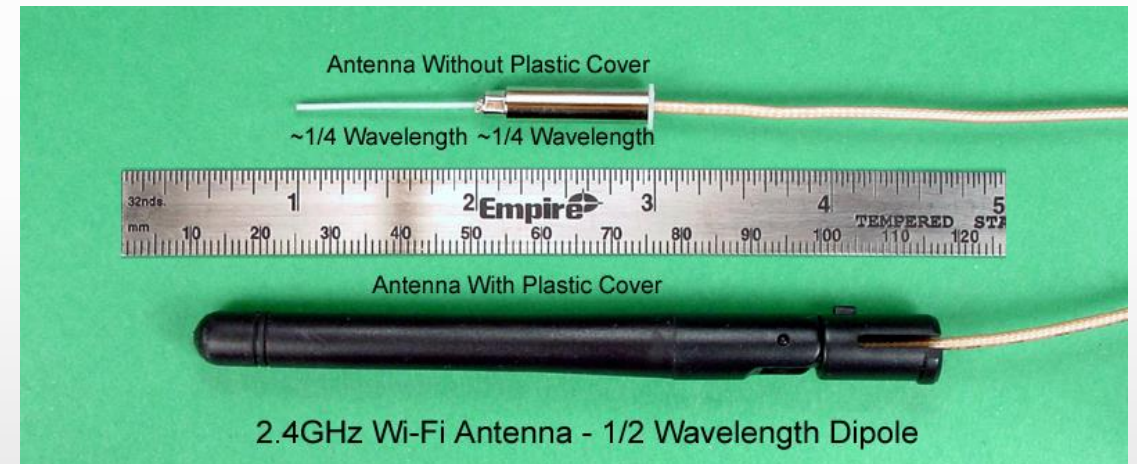

2.4GHz Antenna

Resonance will occur at whole number fractions ($1/2$, $1/3$, $1/4$, etc.) of the fundamental frequency, shorter antennas can be used to send and recover the signal.

A half-wave dipole antenna has a length that is one-half of the fundamental wavelength. It is broken into two quarter-wave lengths called elements. The elements are set at 180 degrees from each other and fed from the middle. This type of antenna is called a center-fed half-wave dipole and shortens the antenna length by half.

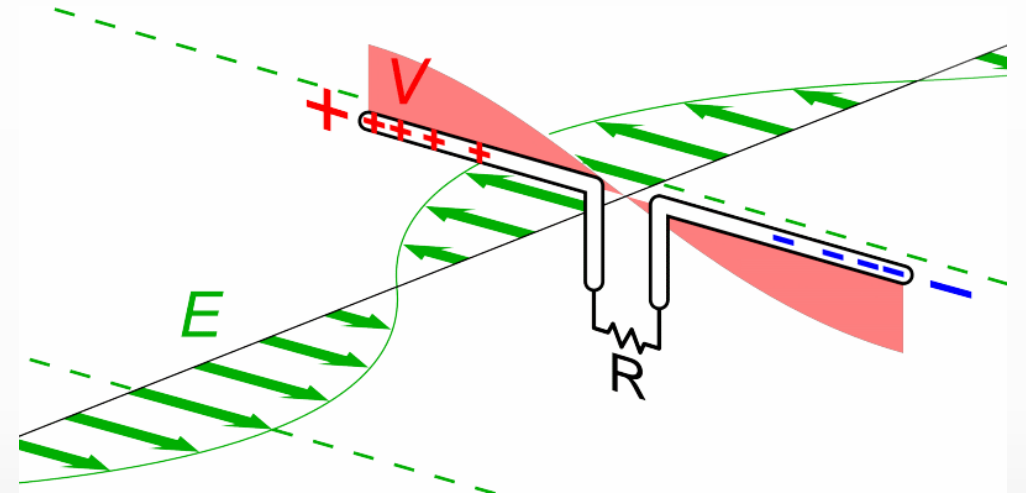
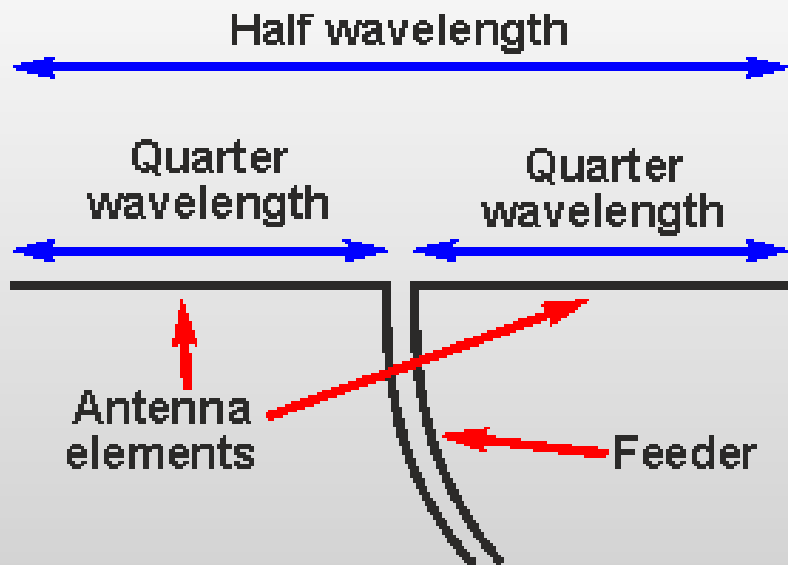

https://upload.wikimedia.org/wikipedia/commons/d/dd/Dipole_receiving_antenna_animation_6_800x394x150ms.gif

2.4GHz PCB Trace Antenna

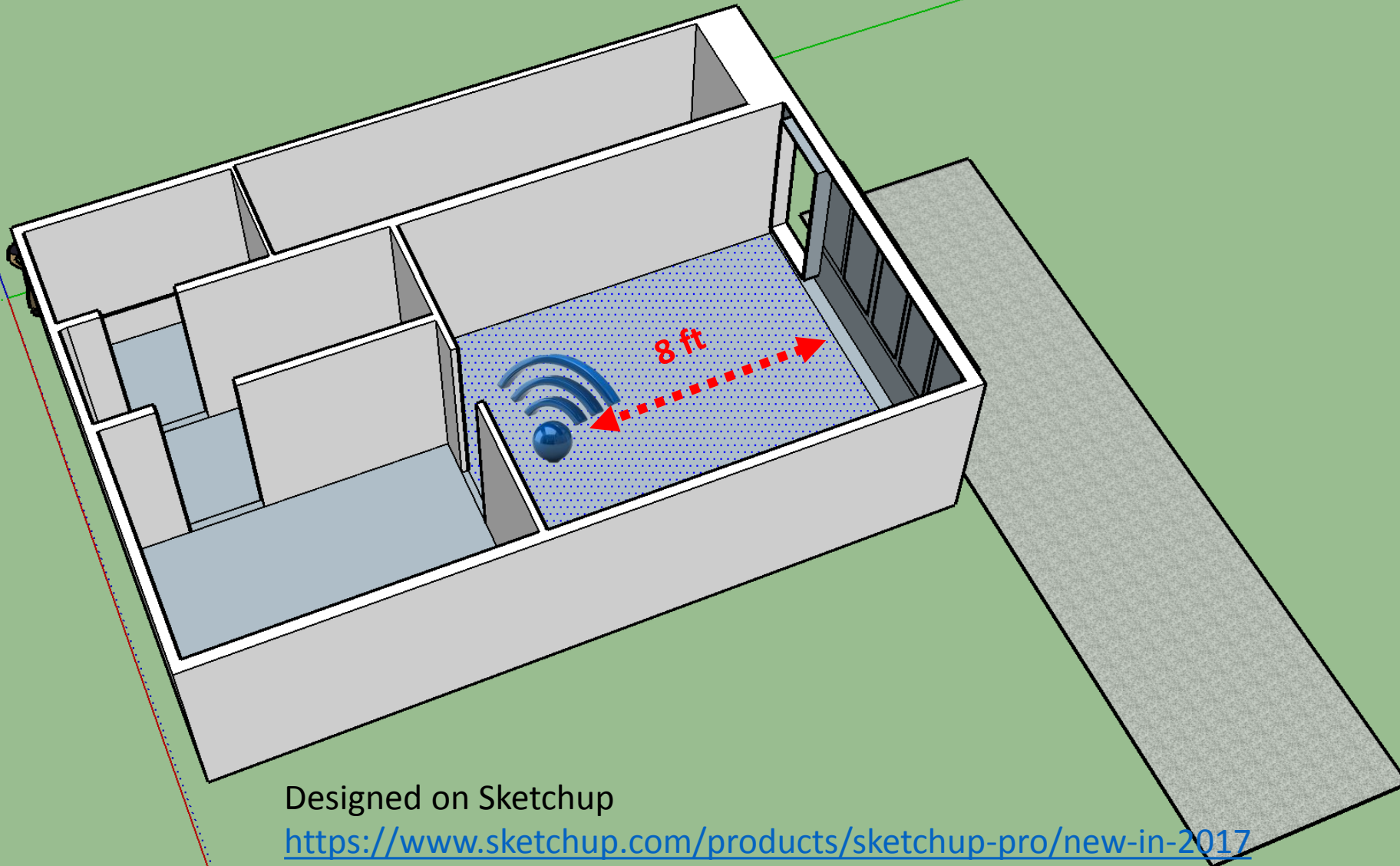

Designed on Sketchup

<https://www.sketchup.com/products/sketchup-pro/new-in-2017>

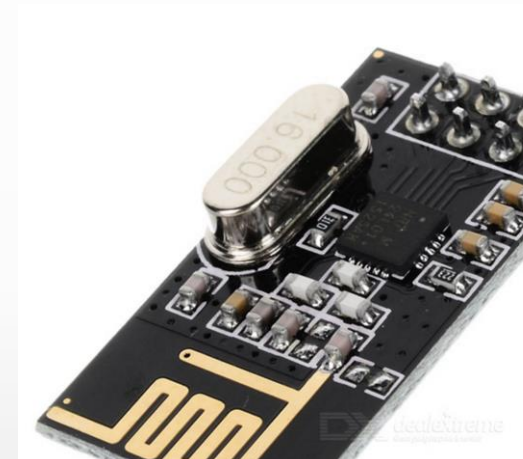

2.4GHz Sparkfun Board With Ceramic Antenna

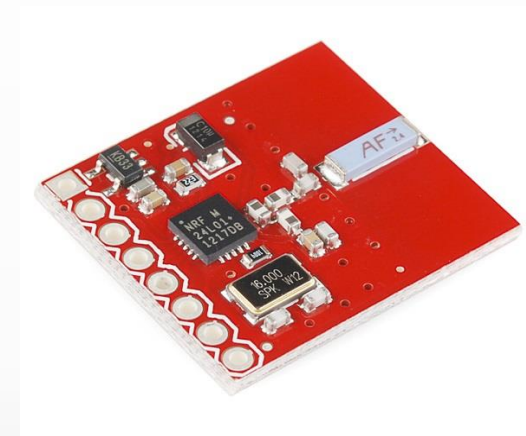
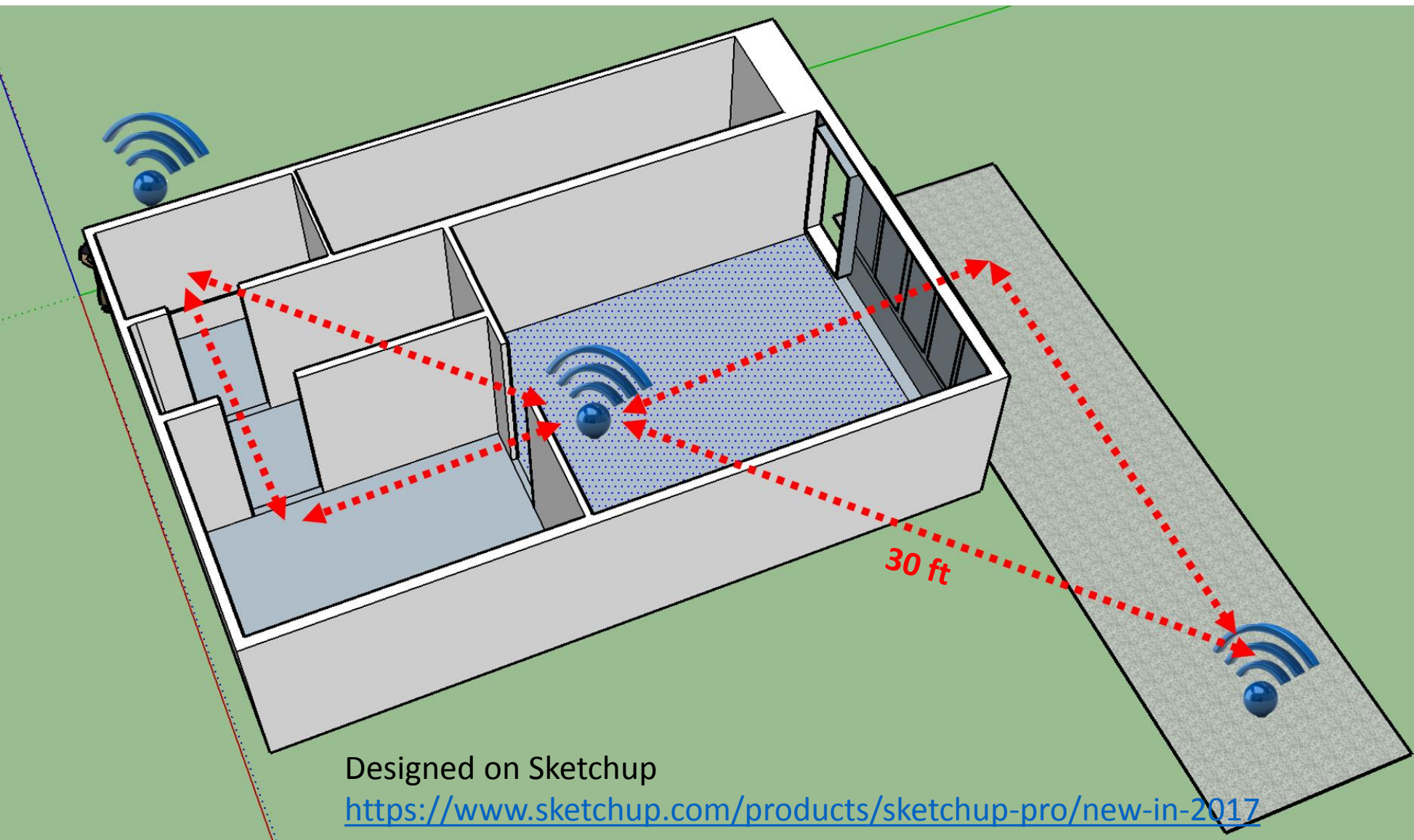

Breakout with SMA-> u.fl adapter -> PCB Antenna

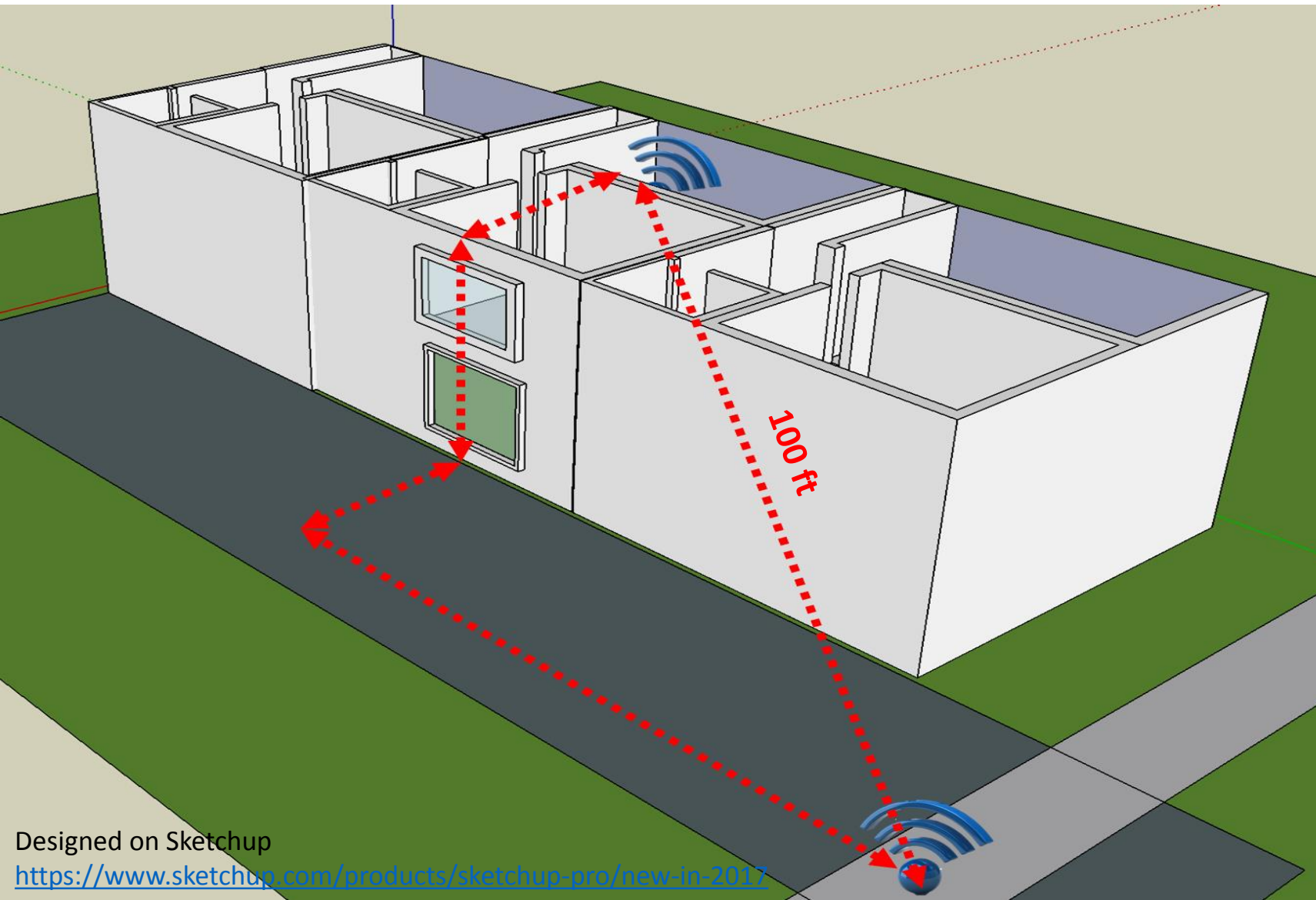

Breakout Rubber Duck Antenna

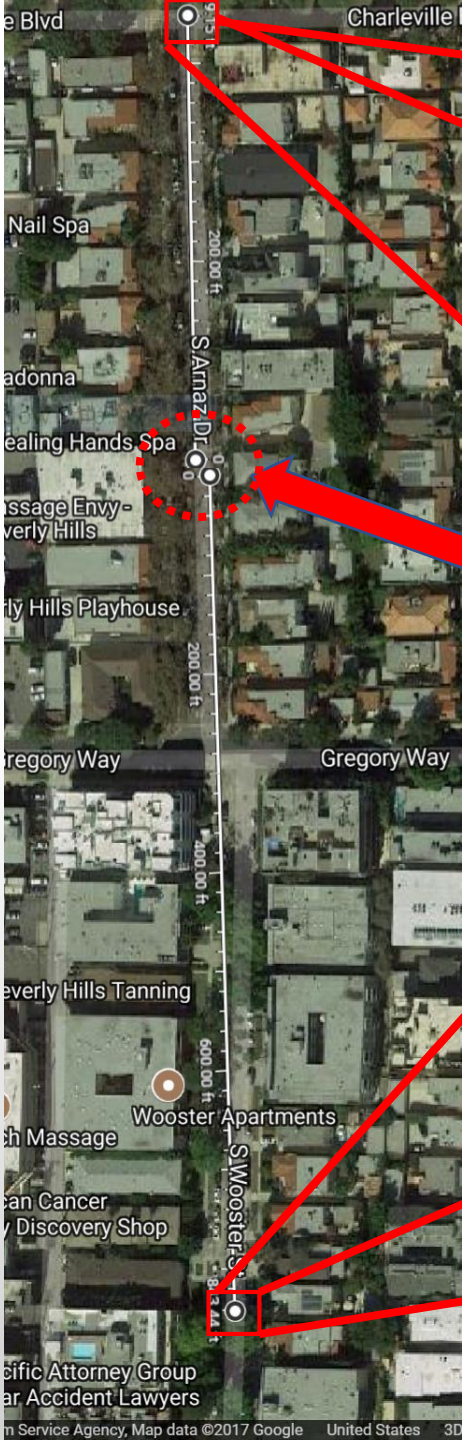

Measure distance
Click on the map to add to your path
Total distance: 458.31 ft (139.69 m)

Origin

Measure distance
Click on the map to add to your path
Total distance: 845.06 ft (257.58 m)



Final Results

**Low Power
6 ft directional**

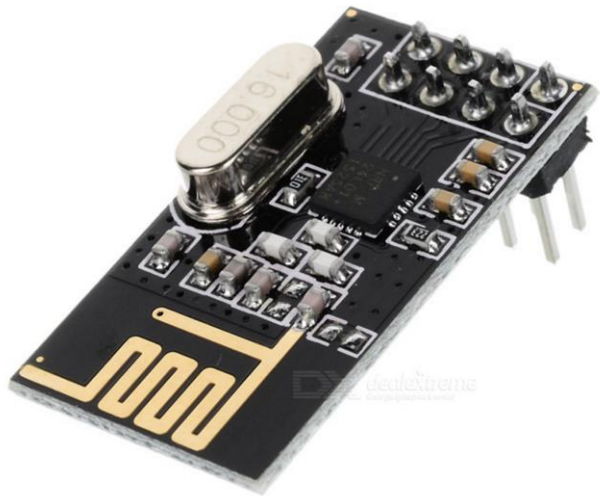

**Medium Power
100 ft**

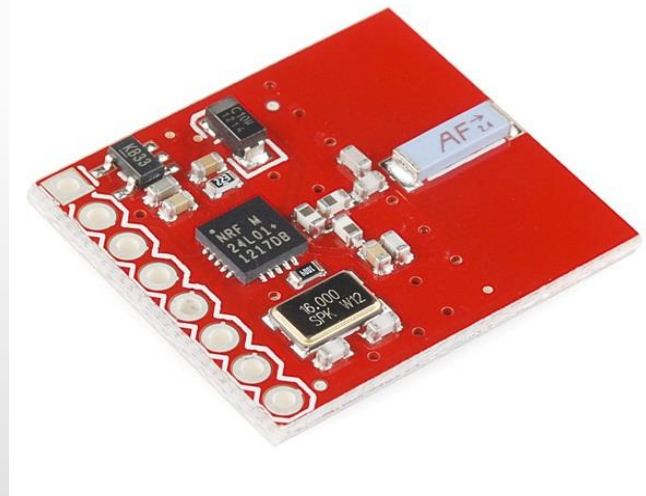

**High Power
850 ft line of
sight**



Rubber Antenna

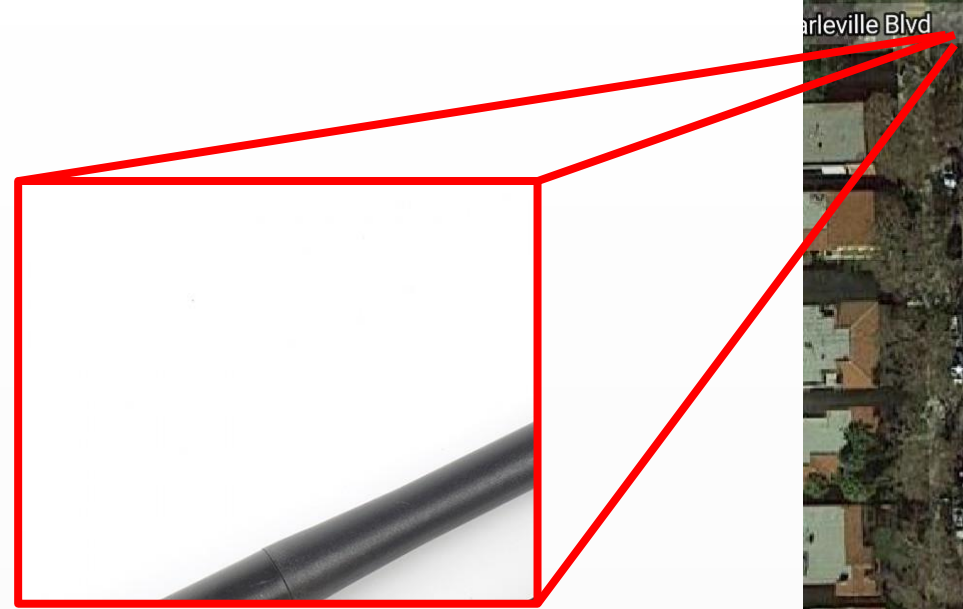
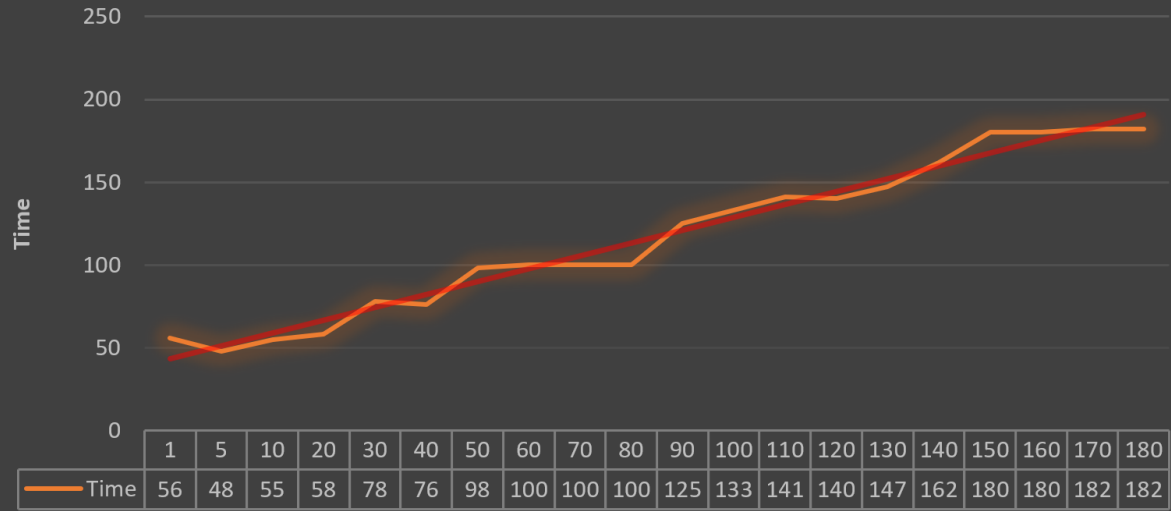

Surface Mount Antenna

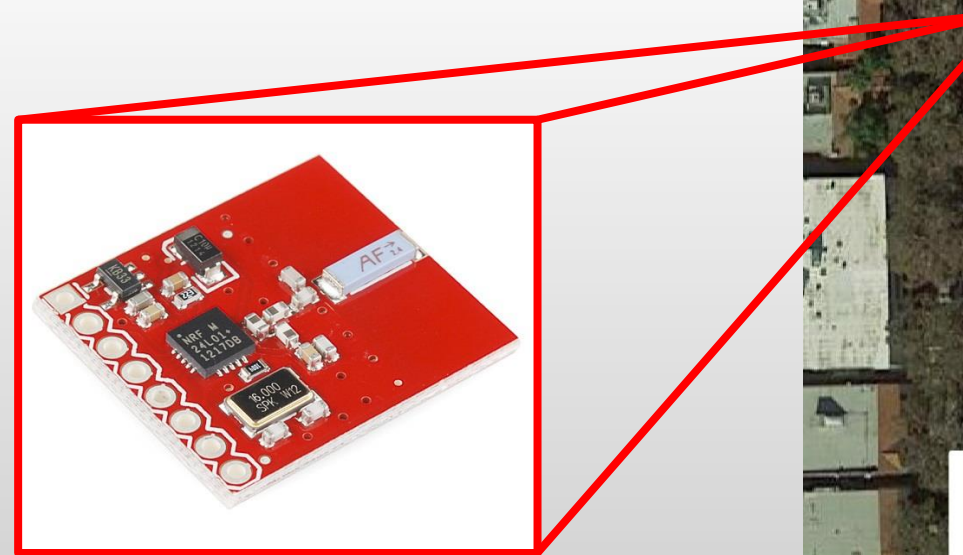
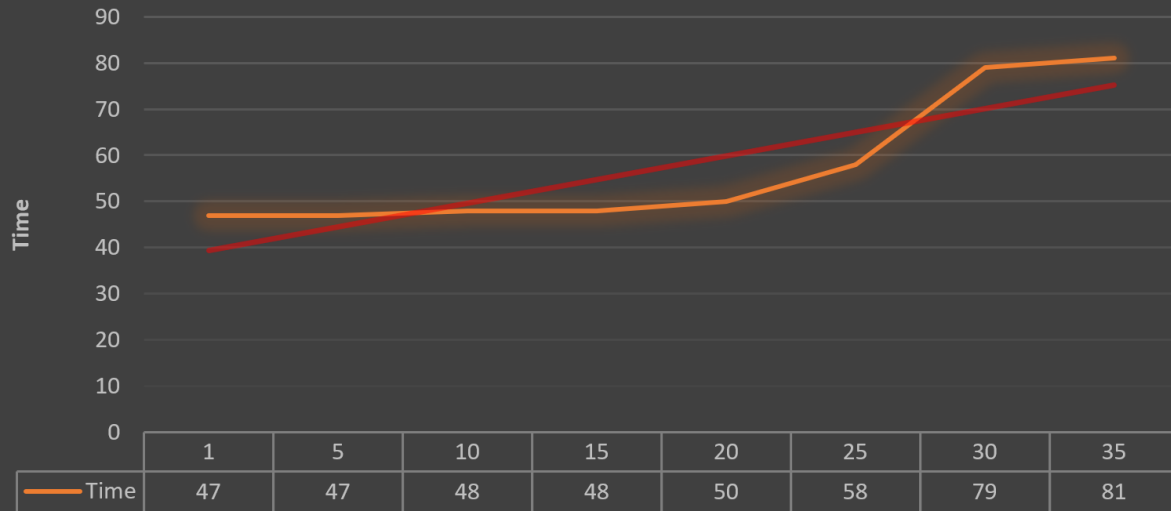

Measure distance
Click on the map to add t
Total distance: 458.31 ft

Trilateration

The process of determining absolute or relative locations of points by measurement of distances, using the geometry of circles, spheres or triangles.

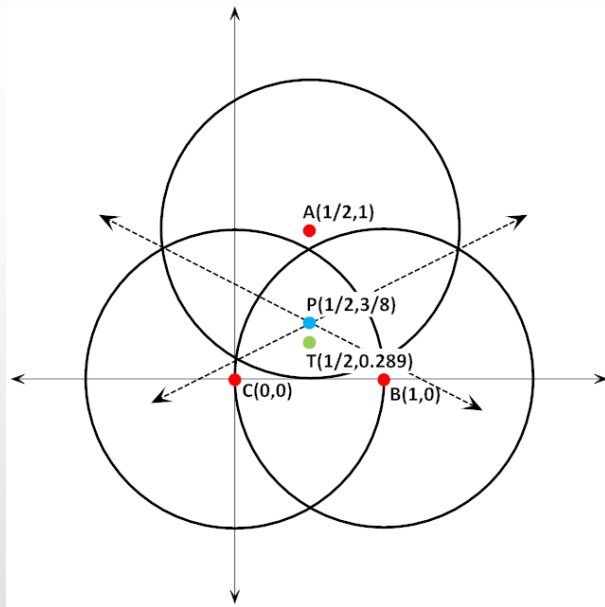

wavelength (in meters) = 300 / frequency (in MHz)

Use the distance equation. If your unknown point is (x, y) , your known points are (x_i, y_i) which are distances r_i from your unknown point, then you get three equations:

$$(x - x_1)^2 + (y - y_1)^2 = r_1^2$$

$$(x - x_2)^2 + (y - y_2)^2 = r_2^2$$

$$(x - x_3)^2 + (y - y_3)^2 = r_3^2$$

We can expand out the squares in each one:

$$x^2 - 2x_1x + x_1^2 + y^2 - 2y_1y + y_1^2 = r_1^2$$

$$x^2 - 2x_2x + x_2^2 + y^2 - 2y_2y + y_2^2 = r_2^2$$

$$x^2 - 2x_3x + x_3^2 + y^2 - 2y_3y + y_3^2 = r_3^2$$

If we subtract the second equation from the first, we get

$$(-2x_1 + 2x_2)x + (-2y_1 + 2y_2)y = r_1^2 - r_2^2 - x_1^2 + x_2^2 - y_1^2 + y_2^2.$$

Likewise, subtracting the third equation from the second,

$$(-2x_2 + 2x_3)x + (-2y_2 + 2y_3)y = r_2^2 - r_3^2 - x_2^2 + x_3^2 - y_2^2 + y_3^2.$$

This is a system of two equations in two unknowns:

$$Ax + By = C$$

$$Dx + Ey = F$$

which has the solution:

$$x = \frac{CE - FB}{EA - BD}$$

$$y = \frac{CD - AF}{BD - AE}$$

Basic Operation

Connections

nRF24s uses SPI to communicate with the Arduino.

They must use Arduino pins 13, 12 and 11 (SCK, MISO and MOSI)

CSN and CE can be connected to any digital pin of the Arduino board and they are used for setting the module in standby or active mode, as well as for switching between transmit or command mode.

IRQ is an interrupt pin which doesn't have to be used.

Power

The nRF24 modules require a 3.3v power supply.

Broadcasting

nRF24L01+ modules broadcast on the 2.4GHz band.

The precise frequency is determined by the channel that is selected.

Both TX and RX must use the same channel.

The default channel for the RF24 library is 76.

When the TX sends a message every RX listening on the same channel will receive the message. The TX includes an "address" in the message and the RX will ignore messages that do not have its address.

Data Packets

The nRF24L01+ modules can transmit a maximum of 32 bytes in a single message.

The nRF24s automatically include sophisticated systems to identify whether the data received matches the data that was sent. If the data is not received correctly the RX will not show data available() and will not send an acknowledgment.

Connections

Referencing Sparkfun Board

- **GND** - Ground
- **IRQ** - Interrupt pin. This pin is active LOW.
- **MISO** - 3.3V-5V tolerant SPI slave output.
- **MOSI** - 3.3V-5V tolerant SPI slave input.
- **SCK** - 3.3V-5V tolerant SPI clock.
- **CSN** - 3.3V-5V tolerant SPI chip select.
- **CE** - 3.3V-5V tolerant chip enable. This pin toggles the nRF24L01+ IC between transmit (TX), receive (RX), standby, and power-down mode.
- **VCC** - This is VRAW and is regulated on-board down to 3.3V for the proper functionality of the nRF24L01+. Voltage range on this pin is **3.3V-7V**.

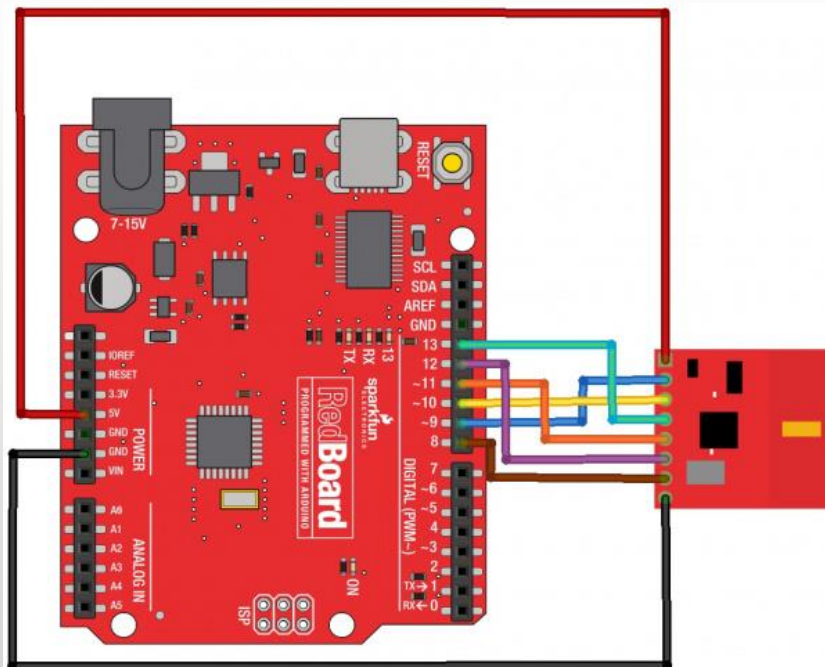

Made with  Fritzing.org

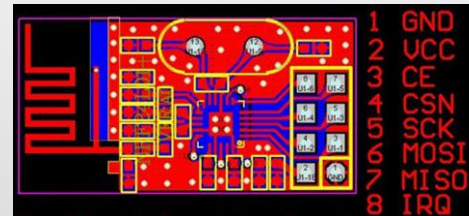
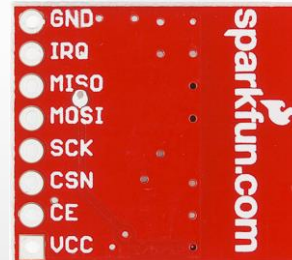

<https://learn.sparkfun.com/tutorials/nrf24l01-transceiver-hookup-guide>
<http://howtomechatronics.com/tutorials/arduino/arduino-wireless-communication-nrf24l01-tutorial/>

Wireless Transceiver Breakout

Benefits

- Ability to connect multiple Arduinos via wireless transmission
- Can be use for sensors such as distance, pressure, temperature, I/O, voltages, etc..
- Control robots
- Monitor rooms in homes, schools, MAZE's, etc...

NRF24L01+

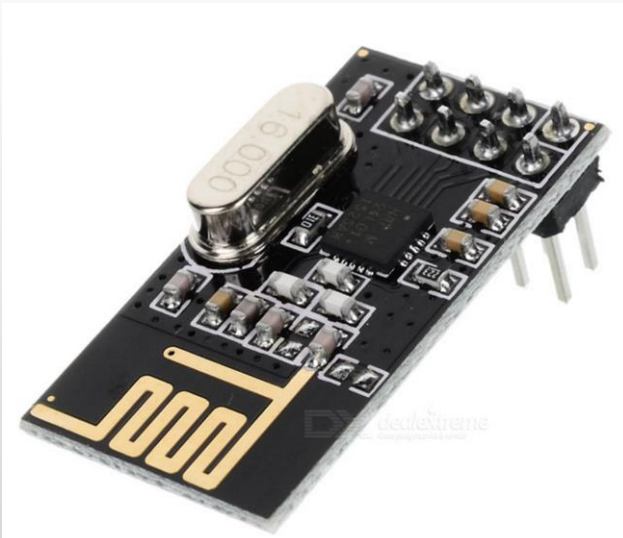

NRF24L01+PA+LNA



SparkFun Transceiver

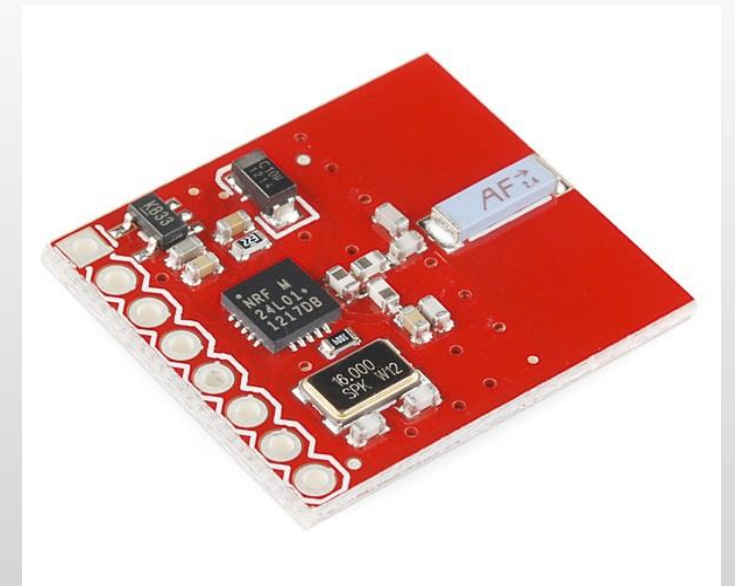

What Else?

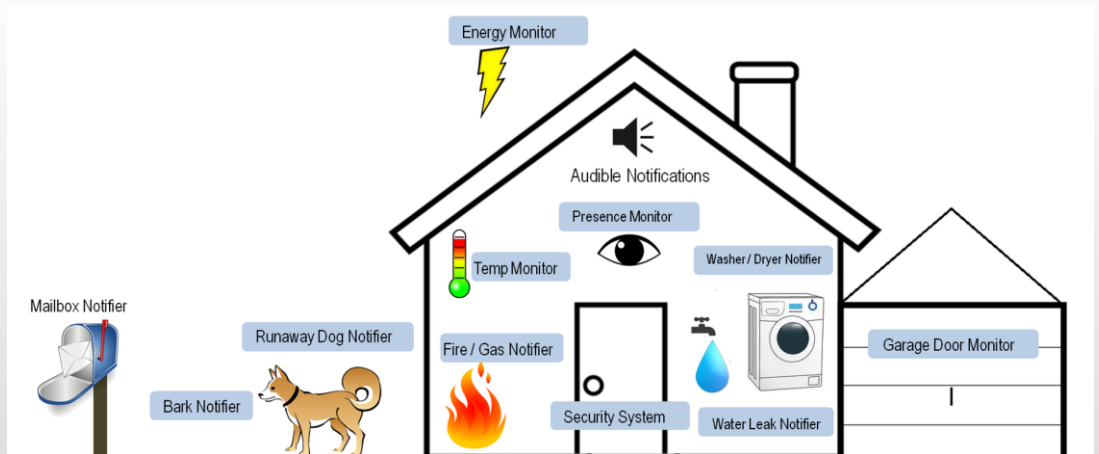
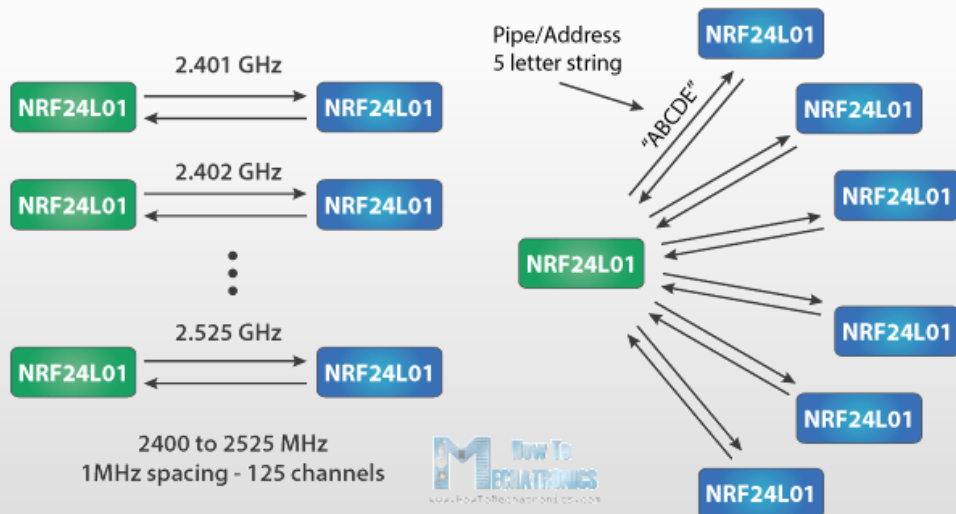

The End

Extra

Example to understand antenna wave lengths

Think of a "sine wave" 12 cm long. Draw it on graph paper if you like. The first half goes positive, the second half goes negative

When catching an RF signal, "negative is just a phase change - you can divide the signal in half (6cm) and say it starts and ends at zero.

Dividing AGAIN for quarter wave (3cm): looking at your graph, the sine wave goes from zero to maximum. At the pointy end of your dipole, no current flows (open circuit) so, applying the sine wave, the other end with a connector has maximum signal current.

Good tutorial and how to video

<http://howtomechatronics.com/tutorials/arduino/arduino-wireless-communication-nrf24l01-tutorial/>

Great site for learning why and getting started

<https://learn.sparkfun.com/tutorials/nrf24l01-transceiver-hookup-guide>

Great site to start with

<https://arduino-info.wikispaces.com/Nrf24L01-2.4GHz-HowTo>

Extra

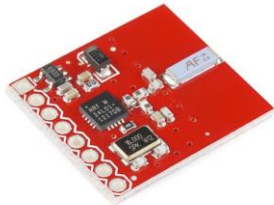

SparkFun Transceiver Breakout - nRF24L01+

WRL-00691 | ROHS ✓
★★★★★ 4

\$19.95

Volume sales pricing

- 1 +

ADD TO CART

Quantity discounts available

Shipping outside of the US? [Click here for info](#)

DESCRIPTION FEATURES DOCUMENTS

This module uses the newest 2.4GHz transceiver from Nordic Semiconductor, the nRF24L01+. This transceiver IC operates in the 2.4GHz band and has many new features! Take all the coolness of the nRF2401A and add some extra pipelines, buffers, and an auto-retransmit feature - very nice!

Please note: We now populate these boards with the nRF24L01+. The 'V' version of the IC has improved range, sensitivity, and data rates. The command set is backward compatible with the original nRF24L01.

Wide Voltage Range



4 Pcs

3-12V

Lenitech 4pcs NRF24L01+ Breakout Adapter with on-board 3.3V Regulator
by Lenitech

\$8.95

prime

Only 14 left in stock - order soon.

15% off item with purchase of 1 items [See Details](#)

Product Features

... markings on board allows for easy connection to the nRF24L01 module.



MakerFocus 2pcs NRF24L01+PA+LNA Wireless Transceiver RF Transceiver Module 2.4G 1100m with Antenna in Antistatic Foam Compatible Arduino

by MakerFocus

\$10.99

prime

Get it by Tomorrow, Oct 31

★★★★★ 35

10% off item with purchase of 1 items and 5 more promotions *

Product Features

... The nRF24L01+ is a 2.4GHz ISM band transceiver, Auto-acknowledge and...

